

# ELECTRIC COOKER INSTRUCTIONS FOR USE

Instructions and advice for installing, using and servicing of cookers.

## FOR HOUSEHOLD USE ONLY

THANK YOU for purchasing this high-quality product.

For future reference, please make a note of your product model and serial numbers. These can be located on the oven frame behind the storage drawer panel.

Model Number \_\_\_\_\_ Serial Number \_\_\_\_\_

### Table of Contents

<b>COOKER SAFETY</b> .....	<b>2</b>
The Anti-Tip Bracket .....	2
<b>USER'S INSTRUCTIONS</b> .....	<b>4</b>
<b>FEATURE GUIDE</b> .....	<b>4</b>
<b>HOB USE</b> .....	<b>5</b>
Cookware .....	7
Home Canning .....	8
<b>OVEN USE</b> .....	<b>8</b>
Electronic Oven Controls .....	8
Aluminum Foil .....	8
Positioning Racks and Bakeware .....	9
Oven Vent .....	9
Baking and Roasting .....	9
Broiling .....	10
Keep Warm .....	10
Cook Time .....	10
<b>COOKER CARE</b> .....	<b>11</b>
Self-Cleaning Cycle .....	11
Steam Clean .....	11
General Cleaning .....	12
Oven Light .....	12
<b>TROUBLESHOOTING</b> .....	<b>13</b>
<b>ACCESSORIES</b> .....	<b>15</b>
<b>ASSISTANCE OR SERVICE</b> .....	<b>15</b>
<b>TECHNICAL FEATURES</b> .....	<b>16</b>
<b>INSTALLATION REQUIREMENTS</b> .....	<b>17</b>
Technical Information .....	17
Tools and Parts .....	17
Electrical Requirements .....	18
<b>INSTALLATION INSTRUCTIONS</b> .....	<b>19</b>
Unpack Cooker .....	19
Install Anti-Tip Bracket .....	19
Electrical Connection .....	21
Verify Anti-Tip Bracket Is Installed and Engaged .....	22
Level Cooker .....	22
Storage Drawer .....	22
Oven Door .....	22
Complete Installation.....	23
Moving the Cooker.....	24

# COOKER SAFETY

## Your safety and the safety of others are very important.

We have provided many important safety messages in this manual and on your appliance. Always read and obey all safety messages.



This is the safety alert symbol.

This symbol alerts you to potential hazards that can kill or hurt you and others.

All safety messages will follow the safety alert symbol and either the word “DANGER” or “WARNING.”

These words mean:

**⚠ DANGER**

You can be killed or seriously injured if you don't immediately follow instructions.

**⚠ WARNING**

You can be killed or seriously injured if you don't follow instructions.

All safety messages will tell you what the potential hazard is, tell you how to reduce the chance of injury, and tell you what can happen if the instructions are not followed.

## The Anti-Tip Bracket

The cooker will not tip during normal use. However, the cooker can tip if you apply too much force or weight to the open door without having the anti-tip bracket fastened down properly.

**⚠ WARNING**

### Tip Over Hazard

A child or adult can tip the cooker and be killed.

Verify the anti-tip bracket has been properly installed and engaged per installation instructions.

Re-engage anti-tip bracket if cooker is moved.

Do not operate cooker without anti-tip bracket installed and engaged.

Failure to follow these instructions can result in death or serious burns to children and adults.

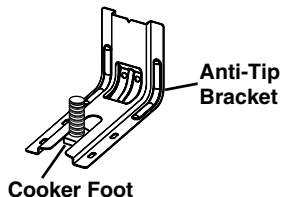
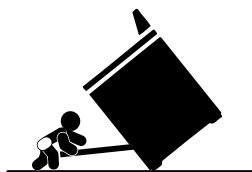

To verify the anti-tip bracket is installed and engaged:

- Slide cooker forward.
- Look for the anti-tip bracket securely attached to floor or wall.
- Slide range back so rear cooker foot is under anti-tip bracket.
- See installation instructions for details.

# IMPORTANT SAFETY INSTRUCTIONS

**WARNING:** To reduce the risk of fire, electrical shock, injury to persons, or damage when using the cooker, follow basic precautions, including the following:

- **WARNING:** TO REDUCE THE RISK OF TIPPING OF THE COOKER, THE COOKER MUST BE SECURED BY PROPERLY INSTALLED ANTI-TIP DEVICES. TO CHECK IF THE DEVICES ARE INSTALLED PROPERLY, SLIDE COOKER FORWARD, LOOK FOR ANTI-TIP BRACKET SECURELY ATTACHED TO FLOOR OR WALL, AND SLIDE COOKER BACK SO REAR COOKER FOOT IS UNDER ANTI-TIP BRACKET.
- **CAUTION:** Do not store items of interest to children in cabinets above a cooker or on the backguard of a cooker – children climbing on the cooker to reach items could be seriously injured.
- Proper Installation – Be sure the cooker is properly installed and grounded by a qualified technician.
- Never Use the Cooker for Warming or Heating the Room.
- **WARNING:** Accessible parts may become hot during use. Young children should be kept away.
- Do Not Leave Children Alone – Children should not be left alone or unattended in area where the cooker is in use. They should never be allowed to sit or stand on any part of the cooker.
- This appliance is not intended for use by persons (including children) with reduced physical, sensory or mental capabilities, or lack of experience and knowledge, unless they have been given supervision or instruction concerning use of the appliance by a person responsible for their safety.
- Children should be supervised to ensure that they do not play with the appliance.
- Wear Proper Apparel – Loose-fitting or hanging garments should never be worn while using the cooker.
- User Servicing – Do not repair or replace any part of the cooker unless specifically recommended in the manual. All other servicing should be referred to a qualified technician.
- Storage in or on the Cooker – Flammable materials should not be stored in an oven or near surface units.
- **Danger** of fire: Do not store items on the cooking surfaces.
- Storage in or on the Cooker - Flammable materials should not be stored in an oven or near surface units.
- **CAUTION:** The cooking process has to be supervised. A short term cooking process has to be supervised continuously.
- **WARNING:** Unattended cooking on a hob with fat or oil can be dangerous and may result in a fire.
- Do Not Use Water on Grease Fires – Smother fire or flame or use dry chemical or foam-type extinguisher.
- Use Only Dry Potholders – Moist or damp potholders on hot surfaces may result in burns from steam. Do not let potholder touch hot heating elements. Do not use a towel or other bulky cloth.
- DO NOT TOUCH SURFACE UNITS OR AREAS NEAR UNITS – Surface units may be hot even though they are dark in color. Areas near surface units may become hot enough to cause burns. During and after use, do not touch, or let clothing or other flammable materials contact surface units or areas near units until they have had sufficient time to cool. Among those areas are the hob and surfaces facing the hob.
- Use Proper Pan Size – The range is equipped with one or more surface units of different size. Select utensils having flat bottoms large enough to cover the surface unit heating element. The use of undersized utensils will expose a portion of the heating element to direct contact and may result in ignition of clothing. Proper relationship of utensil to burner will also improve efficiency.
- Never Leave Surface Units Unattended at High Heat Settings – Boilover causes smoking and greasy spillovers that may ignite.
- Protective Liners – Do not use aluminum foil to line oven bottoms, except as suggested in the manual. Improper installation of these liners may result in a risk of electric shock, or fire.
- Glazed Cooking Utensils – Only certain types of glass, glass/ceramic, ceramic, earthenware, or other glazed utensils are suitable for cooker-top service without breaking due to the sudden change in temperature.
- Utensil Handles Should Be Turned Inward and Not Extend Over Adjacent Surface Units – To reduce the risk of burns, ignition of flammable materials, and spillage due to unintentional contact with the utensil, the handle of a utensil should be positioned so that it is turned inward, and does not extend over adjacent surface units.
- Do Not Cook on Broken Hob – If hob should break, cleaning solutions and spillovers may penetrate the broken cooktop and create a risk of electric shock. Contact a qualified technician immediately.
- **WARNING:** If the surface is cracked, switch off the appliance to avoid the possibility of electric shock for hob surfaces of glass-ceramic or similar material which protect live parts.
- Clean Hob With Caution – If a wet sponge or cloth is used to wipe spills on a hot cooking area, be careful to avoid steam burn. Some cleaners can produce noxious fumes if applied to a hot surface.
- Use Care When Opening Door – Let hot air or steam escape before removing or replacing food.
- Do Not Heat Unopened Food Containers – Build-up of pressure may cause container to burst and result in injury.
- Keep Oven Vent Ducts Unobstructed.
- Placement of Oven Racks – Always place oven racks in desired location while oven is cool. If rack must be moved while oven is hot, do not let potholder contact hot heating element in oven.
- DO NOT TOUCH HEATING ELEMENTS OR INTERIOR SURFACES OF OVEN – Heating elements may be hot even though they are dark in color. Interior surfaces of an oven become hot enough to cause burns. During and after use, do not touch, or let clothing or other flammable materials contact heating elements or interior surfaces of oven until they have had sufficient time to cool. Other surfaces of the appliance may become hot enough to cause burns – among these surfaces are oven vent openings and surfaces near these openings, oven doors, and windows of oven doors.
- **WARNING:** Ensure that the appliance is switched off before replacing the lamp to avoid the possibility of electric shock.

## For self-cleaning ranges –

- Do Not Clean Door Gasket – The door gasket is essential for a good seal. Care should be taken not to rub, damage, or move the gasket.
- Do Not Use Oven Cleaners – No commercial oven cleaner or oven liner protective coating of any kind should be used in or around any part of the oven.
- Clean Only Parts Listed in Manual.
- Before Self-Cleaning the Oven – Remove broiler pan and other utensils.

## SAVE THESE INSTRUCTIONS

# USER'S INSTRUCTION

## FEATURE GUIDE

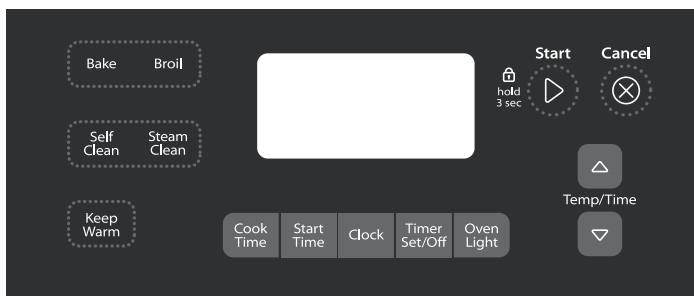

### **⚠ WARNING**

#### **Food Poisoning Hazard**

**Do not let food sit in oven more than one hour before or after cooking.**

**Doing so can result in food poisoning or sickness.**

KEYPAD	FEATURE	INSTRUCTIONS
<b>CLOCK</b>	<b>Clock</b>	The Clock uses a 12-hour cycle. <ol style="list-style-type: none"> <li>1. Check that the oven is off.</li> <li>2. Press <b>CLOCK</b>.</li> <li>3. Press <b>TEMP/TIME</b> “up” or “down” arrow keypad to set the time of day.</li> <li>4. Press <b>CLOCK</b> or <b>START</b>.</li> </ol>
<b>OVEN LIGHT</b>	<b>Oven cavity light</b>	While the oven door is closed, press the oven light switch to turn the light on and off. The oven light will come on when the oven door is opened. The oven light will not come on during the Self-Clean cycle.
<b>TIMER SET/OFF</b>	<b>Oven timer</b>	The Timer can be set in hours or minutes up to 12 hours and 59 minutes. <ol style="list-style-type: none"> <li>1. Press <b>TIMER SET/OFF</b>.</li> <li>2. Press <b>TEMP/TIME</b> “up” or “down” arrow keypad to set the length of time.</li> <li>3. Press <b>START</b> to begin the countdown. If enabled, end-of-cycle tones will sound at end of countdown.</li> <li>4. Press <b>TIMER SET/OFF</b> twice to cancel the Timer. Do not press the <b>Cancel</b> keypad because the oven will turn off.</li> <li>5. If the Timer is running, but not in the display, press <b>TIMER SET/OFF</b> to display the countdown for 5 seconds.</li> </ol>
<b>START</b>	<b>Cooking start</b>	The <b>Start</b> keypad begins any oven function. If <b>Start</b> is not pressed within 5 seconds, “ <b>PUSH</b> ” appears in the display. If <b>Start</b> is not pressed within 1 minute after pressing a keypad, the function is canceled and the time of day is displayed.
<b>CANCEL</b>	<b>Cooker function</b>	The <b>Cancel</b> keypad stops any function, except the <b>Clock</b> , <b>Timer</b> and <b>Oven Control Lockout</b> .
<b>TEMP/TIME</b>	<b>Temperature and time adjust</b>	The “up” and “down” arrow keypads are used to adjust time and temperature settings.
<b>BAKE</b>	<b>Baking and roasting</b>	<ol style="list-style-type: none"> <li>1. Press <b>BAKE</b>.</li> <li>2. Press <b>TEMP/TIME</b> “up” or “down” arrow keypad to set a temperature other than 350°F (175°C) in 5°F (5°C) increments between 170°F and 500°F (75°C and 260°C).</li> <li>3. Press <b>START</b>.</li> <li>4. To change the temperature, repeat Step 2. Press <b>START</b>, or wait 5 seconds for the change to take effect.</li> <li>5. Press <b>CANCEL</b> when finished.</li> </ol>
<b>BROIL</b>	<b>Broiling</b>	<ol style="list-style-type: none"> <li>1. Press <b>BROIL</b>.</li> <li>2. Press <b>TEMP/TIME</b> “up” or “down” arrow keypad to change the temperature in 5°F (5°C) increments between 300°F and 500°F (150°C and 260°C).</li> <li>3. Press <b>START</b>, and then allow oven to preheat for 5 minutes.</li> <li>4. Position cookware in the oven and close the oven door to the broil stop position so that the door is open approximately 6" (15 cm).</li> <li>5. Press <b>CANCEL</b> when finished.</li> </ol>
<b>CONVECT (on some models)</b>	<b>Convection baking and roasting</b>	<ol style="list-style-type: none"> <li>1. Press <b>CONVECT</b>.</li> <li>2. Press <b>TEMP/TIME</b> “up” or “down” arrow keypad to set a temperature other than 350°F (175°C) in 5°F (5°C) increments between 170°F and 500°F (75°C and 260°C).</li> <li>3. Press <b>START</b>.</li> <li>4. To change the temperature, repeat Step 2. Press <b>START</b>, or wait 5 seconds for the change to take effect.</li> <li>5. Press <b>CANCEL</b> when finished.</li> </ol>

# USER'S INSTRUCTION

KEYPAD	FEATURE	INSTRUCTIONS
KEEP WARM	Hold warm	Food must be at serving temperature before placing it in the warmed oven. <ol style="list-style-type: none"><li>1. Press KEEP WARM.</li><li>2. Temperature is set at 170°F (75°C) for 60 minutes (1 hour).</li><li>3. Press START.</li><li>4. Press CANCEL when finished.</li></ol> <b>NOTE:</b> The oven will automatically turn off after 60 minutes.
START TIME	Delayed start	The Start Time keypad is used to enter the starting time for an oven function with a delayed start. Start Time should not be used for foods such as breads and cakes because they may not bake properly. To set a Timed Cook or a Delayed Timed Cook, see "Cook Time" section.
COOK TIME	Timed cooking	Timed cooking allows the oven to be set to turn on at a certain time of day, cook for a set length of time, and/or shut off automatically. To set a Timed Cook or a Delayed Timed Cook, see "Cook Time" section.
SELF CLEAN	Self-cleaning cycle	See the "Self-Cleaning Cycle" section.
STEAM CLEAN	Steam cleaning cycle	See "Steam Clean" section for more information and helpful tips for the Steam Clean feature. <ol style="list-style-type: none"><li>1. Remove all racks and accessories from the oven cavity.</li><li>2. Press STEAM CLEAN. "Add H2O" will appear in the display.</li><li>3. Add 10 oz (295 ml) of distilled or filtered water to the oven bottom.</li><li>4. Push START.</li><li>5. After 20 minutes, "END" will appear in the display to signal the end of the cycle.</li><li>6. Press CANCEL to clear the display.</li><li>7. Remove any excess water with a sponge or cloth, and then wipe down oven interior.</li></ol>
START (hold 3 sec to lock)	Oven control lockout	<ol style="list-style-type: none"><li>1. Check that the oven is off.</li><li>2. Press and hold the START (hold 3 sec to lock) keypad for 3 seconds.</li><li>3. A tone will sound, and "Loc" will be displayed.</li><li>4. Repeat to unlock. Only the Clock, Oven Light and Timer keypads will function with the controls locked. The hob functions are not affected by the oven control lockout.</li></ol>

## HOB USE

**⚠ WARNING**



**Fire Hazard**

**Turn off all controls when done cooking.**

**Failure to do so can result in death or fire.**

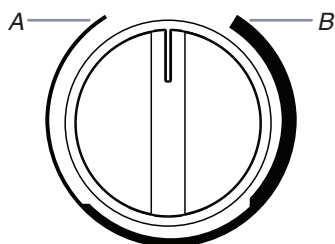

A. Low  
B. High

The control knobs can be set to anywhere between High and Low. Push in and turn to setting.

**REMEMBER:** When cooker is in use, the entire hob area may become hot.

### Ceramic Glass Hob

The surface cooking area will glow red when an element is on. Some parts of the surface cooking area may not glow red when an element is on. This is normal operation. The burner will cycle on and off to maintain the selected heat level. It will also randomly cycle off and back on again even while on High setting to keep the hob from extreme temperatures.

It is normal for the surface of light colored ceramic glass to appear to change color when surface cooking areas are hot. As the glass cools, it will return to its original color.

Clean the hob after each use to help avoid scratches, pitting, abrasions and to condition the glass surface. Ceramic glass hob cleaner and a hob scraper are also recommended for stubborn soils. Do not use abrasive cleaners, cleaning pads or harsh chemicals for cleaning. Refer to the "Cooker Care" section for additional information.

**IMPORTANT:** To avoid permanent damage to the hob surface and to make soils easier to remove, clean the hob after each use to remove all soils.

- The appliance is not intended to be operated by means of an external timer or separated remote-control system.
- Avoid storing jars or cans above the hob. Dropping a heavy or hard object onto the hob could crack the hob.

# USER'S INSTRUCTION

- To avoid damage to the hob, do not leave a hot lid on the hob. As the hob cools, air can become trapped between the lid and the hob, and the ceramic glass could break when the lid is removed.
- For foods containing sugar in any form, clean up all spills and soils as soon as possible. Allow the hob to cool down slightly. Then, while wearing oven mitts, remove the spills using a scraper while the surface is still warm. If sugary spills are allowed to cool down, they can adhere to the hob and can cause pitting and permanent marks.
- To avoid scratches, do not slide cookware or bakeware across the hob. Aluminum or copper bottoms and rough finishes on cookware or bakeware could leave scratches or marks on the hob.
- Do not cook popcorn in prepackaged aluminum containers on the hob. They could leave aluminum marks that cannot be removed completely.
- To avoid damage to the hob, do not allow objects that could melt, such as plastic or aluminum foil, to touch any part of the entire hob.
- To avoid damage to the hob, do not use the hob as a cutting board.
- Use cookware about the same size as the surface cooking area. Cookware should not extend more than ½" (1.3 cm) outside the area.

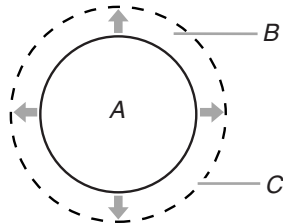

A. Surface cooking area  
B. Cookware/canner  
C. ½" (1.3 cm) maximum overhang

- Use flat-bottomed cookware for best heat conduction and energy efficiency. Cookware with rounded, warped, ribbed or dented bottoms could cause uneven heating and poor cooking results.
- Determine flatness by placing the straight edge of a ruler across the bottom of the cookware. While you rotate the ruler, no space or light should be visible between it and the cookware.
- Cookware designed with slightly indented bottoms or small expansion channels can be used.
- Make sure the bottoms of pots and pans are clean and dry before using them. Residue and water can leave deposits when heated.
- To avoid damage to the hob, do not cook foods directly on the hob.

## Ceramic Glass Hob Cleaning

Clean the hob after each use to help avoid scratches, pitting, abrasions and to condition the glass surface. Ceramic glass hob cleaner and a hob scraper are also recommended for stubborn soils. Do not use abrasive cleaners, cleaning pads or harsh chemicals for cleaning. Refer to the "Cooker Care" section for additional information.

**IMPORTANT:** To avoid permanent damage to the hob surface and to make soils easier to remove, clean the hob after each use to remove all soils.

## Hob On Indicator Light

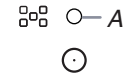

A. Hob on indicator light

The Hob On indicator light is located on the console panel. When any control knob on the console panel is turned on, the Hob On indicator light will glow.

## Hot Surface Indicator Light



A. Hot surface indicator light

On ceramic glass models, the Hot Surface indicator light is located on the console panel.

The Hot Surface indicator light will glow as long as any surface cooking area is too hot to touch, even after the surface cooking area is turned off.

## Dual Zone Cooking Element

The Dual Zone cooking element offers flexibility depending on the size of the cookware. Single size can be used in the same way as a regular element. The dual size combines both the single and outer element and is recommended for larger size cookware.

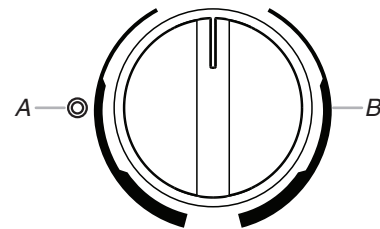

A. Dual  
B. Single

## Warm Zone Element

### ⚠ WARNING

#### Food Poisoning Hazard

**Do not let food sit for more than one hour before or after cooking.**

**Doing so can result in food poisoning or sickness.**

Use the Warm Zone element to keep cooked foods warm. One hour is the recommended maximum time to maintain food quality.

Do not use it to heat cold foods.

The Warm Zone element can be used alone or when any of the other surface cooking areas are being used.

The Warm Zone element area will not glow red when cycling on. However, the Hob On indicator light will glow while the Hob Warm Zone element is in use.

- Use only cookware recommended for oven and hob use.
- Cover all foods with a lid or aluminum foil. When warming baked goods, allow a small opening in the cover for moisture to escape.

# USER'S INSTRUCTION

- To avoid damage to the hob, do not use plastic wrap to cover food because the plastic wrap may melt.
- Use pot holders or oven mitts to remove food.

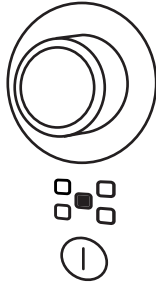

## To Use:

1. To turn on, press Warm Zone push button.
2. To turn off, press Warm Zone push button a second time.

## Cookware

**IMPORTANT:** Do not leave empty cookware on a hot surface cooking area, element or surface burner.

Ideal cookware should have a flat bottom, straight sides and a well-fitting lid, and the material should be of medium-to-heavy thickness.

Rough finishes may scratch the hob. Aluminum and copper may be used as a core or base in cookware. However, when used as a base they can leave permanent marks on the surfaces.

Cookware material is a factor in how quickly and evenly heat is transferred, which affects cooking results. A nonstick finish has the same characteristics as its base material. For example, aluminum cookware with a nonstick finish will take on the properties of aluminum.

Cookware with nonstick surfaces should not be used under the broiler.

Check for flatness by placing the straight edge of a ruler across the bottom of the cookware. While you rotate the ruler, no space or light should be visible between it and the cookware.

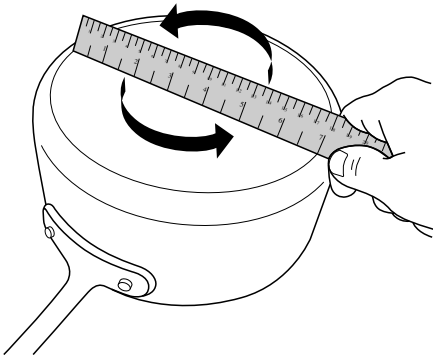

Use the following chart as a guide for cookware material characteristics.

COOKWARE	CHARACTERISTICS
<b>Aluminum</b>	<ul style="list-style-type: none"> <li>■ Heats quickly and evenly.</li> <li>■ Suitable for all types of cooking.</li> <li>■ Medium or heavy thickness is best for most cooking tasks.</li> <li>■ May leave aluminum residues, which may be diminished if cleaned immediately after cooking.</li> </ul>
<b>Cast iron</b>	<ul style="list-style-type: none"> <li>■ Heats slowly and evenly.</li> <li>■ Good for browning and frying.</li> <li>■ Maintains heat for slow cooking.</li> <li>■ Rough edges or burrs may scratch the hob.</li> </ul>

COOKWARE	CHARACTERISTICS
<b>Ceramic or Ceramic glass</b>	<ul style="list-style-type: none"> <li>■ Follow manufacturer's instructions.</li> <li>■ Heats slowly, but unevenly.</li> <li>■ Ideal results on low to medium heat settings.</li> <li>■ May scratch the hob.</li> </ul>
<b>Copper</b>	<ul style="list-style-type: none"> <li>■ Heats very quickly and evenly.</li> <li>■ May leave copper residues, which may be diminished if cleaned immediately after cooking.</li> <li>■ Can leave a permanent stain or bond to the hob if overheated.</li> </ul>
<b>Earthenware</b>	<ul style="list-style-type: none"> <li>■ Follow manufacturer's instructions.</li> <li>■ Use on low heat settings.</li> <li>■ May scratch the hob.</li> </ul>
<b>Porcelain enamel-on-steel or cast iron</b>	<ul style="list-style-type: none"> <li>■ See stainless steel or cast iron.</li> <li>■ Porcelain enamel bakeware without the metal base may bond to the hob if overheated.</li> </ul>
<b>Stainless steel</b>	<ul style="list-style-type: none"> <li>■ Heats quickly, but unevenly.</li> <li>■ A core or base of aluminum or copper on stainless steel provides even heating.</li> </ul>

Use flat-bottomed cookware for best cooking results and energy efficiency. The cookware should be about the same size as the cooking area outlined on the hob. Cookware should not extend more than 1/2" (1.3 cm) outside the area.

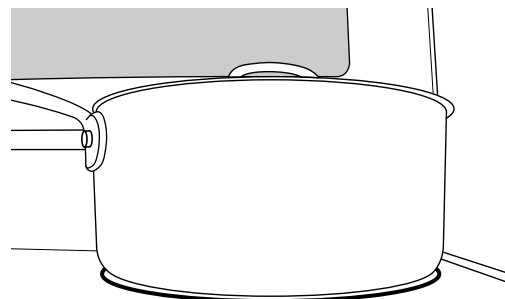

# USER'S INSTRUCTION

## Home Canning

Canning can be performed on a glass smooth top cooking surface or traditional coil element hob. When canning for long periods, alternate the use of surface cooking areas or elements between batches. This allows time for the most recently used areas to cool.

- Center the canner on the largest surface cooking area or element. On electric hobs, canners should not extend more than ½" (1.3 cm) beyond the surface cooking area or element.

- Do not place canner on 2 surface cooking areas or elements at the same time.
- On ceramic glass models, use only flat-bottomed canners to avoid damage to the hob and elements.
- For more information, contact your local agricultural extension office, or refer to published home canning guides. Companies that manufacture home canning products can also offer assistance.

## OVEN USE

Odors and smoke are normal when the oven is used the first few times, or when it is heavily soiled.

**IMPORTANT:** The health of some birds is extremely sensitive to the fumes given off. Exposure to the fumes may result in death to certain birds. Always move birds to another closed and well-ventilated room.

## Electronic Oven Controls

### Control Display

The display will flash when powered up or after a power loss. Press CANCEL to clear. When oven is not in use, the time of day is displayed.

### Options Mode

Press and hold TIMER SET/OFF for 5 seconds, and "Opt" will appear. Use the Temp/Time "up" or "down" arrow keypad to cycle through the following options. Press CANCEL to exit the mode.

### Fahrenheit and Celsius

The temperature is preset at Fahrenheit, but can be changed to Celsius. Press TIMER SET/OFF to toggle between Fahrenheit and Celsius. Press CANCEL to exit.

### End of Cycle Tones

"b1" (beep once) or "b" (continue to beep) will be displayed. Press TIMER to toggle through selections. Press CANCEL to exit.

### Oven Light with Door Open

"LON" indicates that the oven light will turn on when the door is open. If "LOFF" is displayed, the oven light will turn on only with the oven light switch. Press TIMER SET/OFF to toggle through selection. Press CANCEL to exit.

### 12-Hour Shutoff

If "12 Hr" is displayed, the oven will automatically shut off after 12 hours. Press TIMER SET/OFF to toggle to "- - Hr" to disable the 12-hour shutoff. Press CANCEL to exit.

### Tones

Tones are audible signals, indicating the following:

#### Basic Functions

##### One tone

- Valid keypad press
- Oven is preheated (long tone)
- Function has been entered
- Reminder (on some models), repeating every 20 seconds after the end-of-cycle tones

##### Three tones

- Invalid keypad press

##### Four tones

- End of cycle

### Oven Temperature Control

**IMPORTANT:** Do not use a thermometer to measure oven temperature. Elements will cycle on and off as needed to provide consistent temperature but may run slightly hot or cool at any point in time due to this cycling. Most thermometers are slow to react to temperature change and will not provide an accurate reading due to this cycling.

The oven provides accurate temperatures; however, it may cook faster or slower than your previous oven, so the temperature can be adjusted to personalize it for your cooking needs. It can be changed in Fahrenheit or Celsius.

#### To Adjust Oven Temperature:

1. Press and hold BAKE for 5 seconds until the oven display shows the current setting, for example "0°F CAL" or "00."
2. Press the TEMP/TIME "up" or "down" arrow keypad to increase or to decrease the temperature in 10°F (5°C or 6°C) amounts. The adjustment can be set between 30°F and -30°F (17°C and -17°C).
3. Press START.

## Aluminum Foil

**IMPORTANT:** To avoid permanent damage to the oven bottom finish, do not line the oven bottom with any type of foil or liner.

For best cooking results, do not cover entire oven rack with foil because air must be able to move freely.

# USER'S INSTRUCTION

## Positioning Racks and Bakeware

**IMPORTANT:** To avoid permanent damage to the porcelain finish, do not place food or bakeware directly on the oven door or bottom.

### Bakeware

To cook food evenly, hot air must be able to circulate. Allow 2" (5 cm) of space around bakeware and oven walls. Make sure that no bakeware piece is directly over another.

### Racks

- Position racks before turning on the oven.
- Do not move racks with bakeware on them.
- Make sure racks are level.

To move a rack, pull it out to the stop position, raise the front edge, and then lift out. Use the following illustrations and charts as a guide.

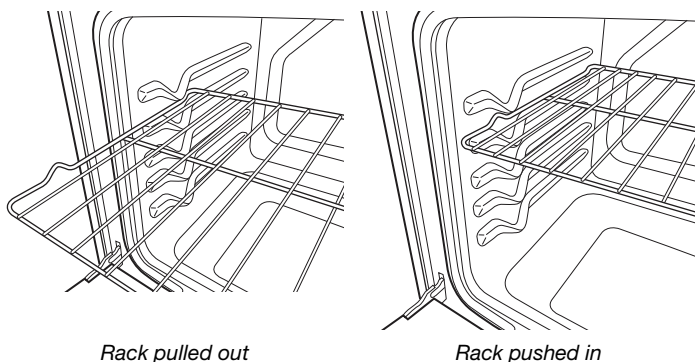

### Rack Positions

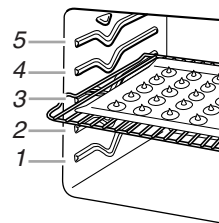

Rack 5: Toasting bread or broiling thin, non-fatty foods.

Rack 4: Use for 2-rack baking and broiling.

Rack 3: Most baked goods on a cookie sheet, muffin pan or jelly roll pan; and layer cakes. Broiling chicken pieces.

Rack 2: Pies, casseroles, yeast bread, quick breads, frozen convenience foods, and 2-rack baking.

Rack 1: Roasting large and small cuts of meat and poultry.

### Multiple Rack Cooking

2-rack: Use rack positions 2 and 4.

### Baking Layer Cakes on 2 Racks

For best results when baking cakes on 2 racks, use racks 2 and 4 for baking. Place the cakes on the racks as shown.

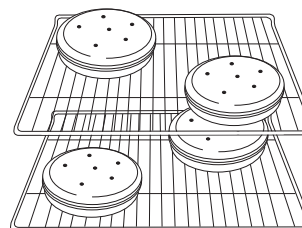

## Oven Vent

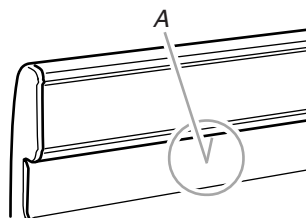

A. Oven vent

The oven vent releases hot air and moisture from the oven, and should not be blocked or covered. Blocking or covering the vent will cause poor air circulation, affecting cooking and cleaning results. Do not set plastics, paper or other items that could melt or burn near the oven vent.

## Baking and Roasting

### 6<sup>th</sup> Sense® Temperature Management System

The 6<sup>th</sup> Sense® system electronically regulates the oven heat levels during preheat and bake to maintain a precise temperature range for optimal cooking results. The bake and broil elements cycle on and off in intervals. The bake element will glow red when cycling on; the broil element will not. This feature is automatically activated when the oven is in use.

Before baking and roasting, position racks according to "Positioning Racks and Bakeware" section. When roasting, it is not necessary to wait for the oven preheat cycle to end before putting food in unless it is recommended in the recipe.

### Preheating

When START is pressed, the oven will begin preheating. Once 100°F (38°C) is reached, the display temperature will increase as the actual temperature of the oven increases. When the preheat temperature is reached, a tone will sound, and the selected temperature will appear on the display.

# USER'S INSTRUCTION

## Broiling

Leave the door open 6" (15 cm) at the broil stop position to ensure proper broiling temperature. Preheat the oven for 5 minutes before putting food in unless recommended otherwise in the recipe. Position food on grid in a broiler pan, then place it in the center of the oven rack.

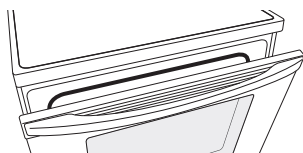

**NOTE:** Odors and smoke are normal the first few times the oven is used or if the oven is heavily soiled.

Changing the temperature when broiling allows more precise control when cooking. The lower the broil setting, the slower the cooking. Thicker cuts and unevenly shaped pieces of meat, fish and poultry may cook better at lower broil settings. Use racks 4 or 5 for broiling. Refer to the "Positioning Racks and Bakeware" section for more information.

On lower settings, the broil element will cycle on and off to maintain the proper temperature.

## Keep Warm

### **⚠ WARNING**

#### **Food Poisoning Hazard**

**Do not let food sit in oven more than one hour before or after cooking.**

**Doing so can result in food poisoning or sickness.**

**IMPORTANT:** Food must be at serving temperature before placing it in the warmed oven. Food may be held up to 1 hour; however, breads and casseroles may become too dry if left in the oven during the Keep Warm function. For best results, cover food.

The Keep Warm feature allows hot cooked foods to stay at serving temperature.

#### **To Use:**

1. Press KEEP WARM.
2. Press the TEMP/TIME "up" or "down" arrow keypad to enter a temperature other than the one displayed. The temperature can be set from 145°F to 190°F (63°C to 85°C).

**NOTE:** The temperature may be changed at any time by pressing the TEMP/TIME "up" or "down" arrow keypad to change the displayed temperature and then START.

3. Press START.
4. Place the food in the oven.
5. Press CANCEL when finished.
6. Remove food from the oven.

#### **To Cancel Keep Warm Feature:**

Press CANCEL. Remove food from oven.

## Cook Time

### **⚠ WARNING**

#### **Food Poisoning Hazard**

**Do not let food sit in oven more than one hour before or after cooking.**

**Doing so can result in food poisoning or sickness.**

#### **To Set a Timed Cook:**

1. Press BAKE. The Bake indicator light will light up.
2. Press the TEMP/TIME "up" or "down" arrow keypad to enter a temperature other than the one displayed.
3. Press COOK TIME. The Cook Time oven indicator light will light up.
4. Press the TEMP/TIME "up" or "down" arrow keypad to enter the length of time to cook.
5. Press START. The display will count down the time. When the time ends, the oven will shut off automatically and "End" will appear on the display.
6. Press CANCEL to clear the display.

#### **To Set a Delayed Timed Cook:**

Before setting, make sure the clock is set to the correct time of day. See the "Clock" keypad feature in the "Feature Guide" section.

1. Press BAKE.
2. Press the TEMP/TIME "up" or "down" arrow keypad to enter a temperature other than the one displayed.
3. Press COOK TIME. The Cook Time oven indicator light will light up.
4. Press TEMP/TIME "up" or "down" arrow keypad to enter the length of time to cook.
5. Press START TIME. The Start Time/Delay Oven indicator light will light up.
6. Press TEMP/TIME "up" or "down" arrow keypad to enter the time of day to start.
7. Press START.

When the start time is reached, the oven will automatically turn on. The temperature and/or time settings can be changed anytime after pressing Start by repeating steps 1 through 7. When the set cook time ends, the oven will shut off automatically and "End" will appear on the display.

8. Press CANCEL to clear the display.

# USER'S INSTRUCTION

## COOKER CARE

### Self-Cleaning Cycle

#### **WARNING**



#### **Burn Hazard**

**Do not touch the oven during the Self-Cleaning cycle.**

**Keep children away from oven during Self-Cleaning cycle.**

**Failure to follow these instructions can result in burns.**

**IMPORTANT:** The health of some birds is extremely sensitive to the fumes given off during the Self-Cleaning cycle. Exposure to the fumes may result in death to certain birds. Always move birds to another closed and well-ventilated room.

Do not block the oven vent(s) during the Self-Cleaning cycle. Air must be able to move freely. Depending on your model, see "Oven Vent" section.

Do not clean, rub, damage or move the oven door gasket.

#### **Prepare Cooker**

- Remove the broiler pan, grid, cookware and bakeware, all cooking utensils, oven racks and aluminum foil and, on some models, the temperature probe from the oven.
- Use a damp cloth to clean inside door edge and the 1½" (3.8 cm) area around the inside oven cavity frame, being certain not to move or bend the gasket.
- Remove plastic items from the hob because they may melt.
- Remove all items from the storage drawer.
- Excess spillage must be removed before cleaning.

#### **How the Cycle Works**

**IMPORTANT:** The heating and cooling of porcelain on steel in the oven may result in discoloring, loss of gloss, hairline cracks and popping sounds.

Before self-cleaning, make sure the door is completely closed or the door will not lock and the self-cleaning cycle will not begin.

Once the oven has completely cooled, remove ash with a damp cloth. To avoid breaking the glass, do not apply a cool, damp cloth to the inner door glass before it has completely cooled.

To stop the self-cleaning cycle at anytime, press CANCEL. If the temperature is too high, the oven door will remain locked and "cool" and "locked" will be displayed.

The oven light will not function during the self-cleaning cycle.

#### **Electronic Oven Control with Adjustable Clean Time**

The Self Clean self-cleaning cycle is time adjustable between 2 hours 30 minutes and 4 hours 30 minutes in 15-minute increments. Under such conditions, the surfaces may get hotter than usual. Suggested clean times are 2 hours 30 minutes for light soil, and 4 hours 30 minutes for heavy soil. The last 30 minutes of the cycle is for cool down.

#### **To Self-Clean:**

1. Press SELF CLEAN.
2. Press the TEMP/TIME "+" or "-" arrow keypad to enter the desired self-clean cycle time.
3. Press START.  
The oven door will automatically lock. The Door Locked and Clean indicator lights will turn on. The time remaining will also be displayed.
4. When the self-clean cycle is complete and the oven cools, the Door Locked and Clean indicator lights will turn off.
5. When the oven is completely cooled, remove ash with a damp cloth.

### Steam Clean

**IMPORTANT:** Do not use oven cleaners or any other additives with Steam Clean.

The Steam Clean feature is designed for light oven cavity bottom cleaning. Use the Steam Clean feature as soon as possible after spills occur. The longer a spill sits and dries in the oven, the more difficult it may be to remove.

Allow the cooker to cool to room temperature before using the Steam Clean feature. If your oven cavity is above 170°F (77°C), "HOT" will appear in the display, and the Steam Clean feature will not activate until it cools down.

- Remove all racks and accessories from the oven cavity.
- For best results, pour 10 oz (295 ml) of distilled or filtered water onto the oven bottom.
- The Steam Clean feature will take a total of 20 minutes. "End" will appear in the display at the end of the cycle.

**IMPORTANT:** Since the water in the oven bottom is hot, do not open the oven door during the Steam Clean cycle.

Press CANCEL at any time to end the cycle. The display will return to the time of day.

#### **Helpful Hints**

- Once the Steam Clean cycle is complete, remove all remaining water and debris in the bottom of the oven with a sponge or cloth.
- Wipe any remaining moisture from the oven door interior, oven cavity interior sides, and hob.
- Use a soft brush or nylon scrubber to wipe the oven interior. This may help with more stubborn stains.
- If any soil remains, run a second Steam Clean cycle to help loosen debris for easier removal.
- Use the Steam Clean on small spills such as cheese or sauce from pizza or snacks, or drips from casseroles.
- Food spills containing sugar, proteins or starches may require vigorous scrubbing to remove most of the debris.
- It is recommended to use distilled or filtered water, as tap water may leave mineral deposits on the oven bottom. Use a cloth soaked with vinegar or lemon juice to remove any mineral deposits that may be left after the Steam Clean cycle.
- If the oven is heavily soiled, use the Self-Clean cycle. The Steam Clean cycle may be used first to eliminate most of the debris, resulting in a more effective self-clean.

# USER'S INSTRUCTION

## General Cleaning

**IMPORTANT:** Before cleaning, make sure all controls are off and the oven and hob are cool. Always follow label instructions on cleaning products. A steam cleaner is not to be used.

Soap, water and a soft cloth or sponge are suggested first unless otherwise noted.

### EXTERIOR PORCELAIN ENAMEL SURFACES

Food spills containing acids, such as vinegar and tomato, should be cleaned as soon as the entire cooker is cool. These spills may affect the finish.

#### Cleaning Method:

- Glass cleaner, mild liquid cleaner or nonabrasive scrubbing pad: Gently clean around the model and serial number plate because scrubbing may remove numbers.

### STAINLESS STEEL (on some models)

**NOTE:** To avoid damage to stainless steel surfaces, do not use soap-filled scouring pads, abrasive cleaners, Hob Cleaner, steel-wool pads, gritty washcloths or abrasive paper towels. Damage may occur to stainless steel surfaces, even with one-time or limited use.

#### Cleaning Method:

- Rub in direction of grain to avoid damaging.

### METALLIC PAINT (on some models)

Do not use abrasive cleaners, cleaners with bleach, rust removers, ammonia or sodium hydroxide (lye) because paint surface may stain.

### CERAMIC GLASS

#### Cleaning Method:

Use Hob Cleaner and Hob Scraper to clean and remove stains from the hob. Use Hob Protectant regularly to avoid stain buildup, pitting and scratching, while conditioning the hob for easier future cleaning. These can be ordered as accessories. See the "Accessories" section for more information. The Hob Scraper uses razor blades. Store razor blades out of the reach of children.

Do not use steel wool, abrasive powder cleansers, chlorine bleach, rust remover or ammonia because damage may occur.

#### Light to moderate soil

- Can be cleaned with damp paper towels or sponge. Light stains should be addressed with cleaner and cleaning pad.

#### Sugary spills (jellies, candy, syrup)

- Clean with hob scraper and hob cleaner. Scrape off sugary spills while the hob is still warm. You may want to wear oven mitts while cleaning the hob.

#### Heavy soil, dark streaks, specks and discoloration

- Clean with Hob Cleaner or nonabrasive cleaner and cleaning pad.

#### Burned-on soil

- Clean with Hob Cleaner, Cleaning Pad and Hob Scraper.

#### Metal marks from aluminum and copper

- Clean with Hob Cleaner and Cleaning Pad as soon as hob has cooled down. The marks will not totally disappear, but after many cleanings they will become less noticeable.

### Tiny scratches and abrasions

- Use Hob Cleaner and Cleaning Pad for scratches. Scratches and abrasions do not affect cooking performance, and after many cleanings they will become less noticeable.

### HOB CONTROLS

To avoid damage to the hob controls, do not use steel wool, abrasive cleansers or oven cleaner.

To avoid damage, do not soak knobs.

When replacing knobs, make sure knobs are in the Off position.

On some models, do not remove seals under knobs.

#### Cleaning Method:

- Soap and water:  
Pull knobs straight away from control panel to remove.

### CONTROL PANEL AND OVEN DOOR EXTERIOR

To avoid damage to the control panel, do not use abrasive cleaners, steel-wool pads, gritty washcloths or abrasive paper towels.

#### Cleaning Method:

- Glass cleaner and soft cloth or sponge:  
Apply glass cleaner to soft cloth or sponge, not directly on panel.

### OVEN DOOR

Do not use harsh abrasive cleaners or sharp metal scrapers to clean the oven door glass since they can scratch the surface, which may result in shattering of the glass.

#### Cleaning Method:

- Can be cleaned with damp paper towels or sponge.

### OVEN RACKS

#### Cleaning Method:

- Steel-wool pad
- For racks that have discolored and are harder to slide, a light coating of vegetable oil applied to the rack guides will help them slide.

### STORAGE DRAWER

Check that storage drawer is cool and empty before cleaning.

#### Cleaning Method:

- Mild detergent

### OVEN CAVITY

Do not use oven cleaners on models with self-clean.

Food spills should be cleaned when oven cools. At high temperatures, foods react with porcelain and staining, etching, pitting or faint white spots can result.

#### Cleaning Method:

- See the "Self-Cleaning Cycle" section.

## Oven Light

The oven light is a standard 40-watt appliance bulb. Before replacing, make sure the oven and hob are cool and the control knobs are in the off position.

#### To Replace:

1. Unplug cooker or disconnect power.

2. Turn the glass bulb cover in the back of the oven counterclockwise to remove.
3. Turn bulb counterclockwise to remove from socket.
4. Replace bulb, then bulb cover by turning clockwise.
5. Plug in cooker or reconnect power.

# USER'S INSTRUCTION

## TROUBLESHOOTING

First try the solutions suggested here to possibly avoid the cost of a service call.

### Operation

PROBLEM	POSSIBLE CAUSES	SOLUTIONS
<b>Nothing will operate</b>	Power supply cord is unplugged.	Plug into a grounded outlet.
	Household fuse is blown, or a circuit breaker is tripped.	Replace the fuse or reset the circuit breaker. If the problem continues, call an electrician.
	The control displays an F9 or F9 E0 error code.	The electrical outlet in the home may be miswired. Contact a qualified electrician to verify the electrical supply.
<b>Hob will not operate</b>	The control knob is not set correctly.	Push in knob before turning to a setting.
	On ceramic glass models, the oven control lockout is set.	See the control lock keypad feature in the "Feature Guide" section.
<b>Excessive heat around cookware on hob</b>	Cookware is not the proper size.	Use cookware about the same size as the surface cooking area, element or surface burner. Cookware should not extend more than ½" (1.3 cm) outside the cooking area.
<b>Hob cooking results not what expected</b>	Control knob set to incorrect heat level.	See "Hob Use" section.
	Cooker is not level.	Level the cooker. See the "Installation Instructions" section.
<b>Hob element cycles on and off on High setting</b>	Element cycling due to a temperature limiter	This is normal operation. The element may cycle on and off to keep the hob from overheating.
<b>Oven will not operate</b>	Delay Start is set.	See "Cook Time" section.
	Control Lock is on.	Press and hold START for 3 seconds to unlock.
	Control is in Demo Mode.	Press and hold START TIME for 10 seconds to exit Demo Mode. Demo Mode is used for display models in a showroom.
	Electronic oven control set incorrectly	See "Electronic Oven Controls" section.
<b>Oven temperature too high or too low</b>	Oven temperature needs adjustment.	See "Oven Temperature Control" in the "Electronic Oven Controls" section.
<b>Oven indicator lights flash</b>	Power to cooker is turned on or restored.	See "Control Display" in the "Electronic Oven Controls" section. If the indicator lights keep flashing, call for service.
<b>Display shows messages</b>	Power failure (display shows flashing time)	Clear the display. On some models, reset the clock, if needed. See "Clock" keypad feature in the "Feature Guide" section.
	Error code (display shows letter followed by number)	Depending on your model, press CANCEL to clear the display. See "Control Display" in the "Electronic Oven Controls" section. If it reappears, call for service.
	Start needs to be pressed so a cycle can begin (display shows "PUSH" or "PSH").	See the "Start" keypad feature in the "Feature Guide" section.
<b>Self-Cleaning cycle will not operate</b>	The oven door is not closed.	Make sure the oven door is fully closed.
	The Self-Cleaning function has not been entered correctly.	See the "Self-Cleaning Cycle" section.
	A timed cooking function has been entered.	See the "Cook Time" section.
<b>Mineral deposits are left on the oven bottom after the Steam Clean cycle</b>	Tap water was used in the Steam Clean cycle.	Use distilled or filtered water in the Steam Clean cycle. To remove deposits, use a cloth soaked with vinegar. Then use a cloth dampened with water to thoroughly remove any vinegar residue.
	Cooker is not level.	Mineral deposits will collect on dry areas of the oven bottom during the Steam Clean cycle. Level the cooker. See the "Installation Instructions" section. To remove deposits, use a cloth soaked with vinegar. Then use a cloth dampened with water to thoroughly remove any vinegar residue.

# USER'S INSTRUCTION

PROBLEM	POSSIBLE CAUSES	SOLUTIONS
<b>Oven cooking results not what expected</b>	Cooker is not level.	Level the cooker. See the "Installation Instructions" section.
	The temperature set was incorrect.	Double-check the recipe in a reliable cookbook.
	Oven temperature needs adjustment.	See "Oven Temperature Control" in the "Electronic Oven Controls" section.
	Oven was not preheated.	See "Baking and Roasting" section.
	Racks were positioned improperly.	See "Positioning Racks and Bakeware" section.
	Not enough air circulation around bakeware.	See "Positioning Racks and Bakeware" section.
	Batter distributed unevenly in pan	Check that batter is level in the pan.
	Darker browning of food caused by dull or dark bakeware	Lower oven temperature 25°F (15°C) or move rack to a higher position in the oven.
	Lighter browning of food caused by shiny or light colored bakeware	Move rack to a lower position in the oven.
	Incorrect length of cooking time was used.	Adjust cooking time.
	Oven door was not closed.	Be sure that the bakeware does not keep the door from closing.
	Oven door was opened during cooking.	Oven peeking releases oven heat and can result in longer cooking times.
	Rack is too close to bake burner, making baked items too brown on bottom.	Move rack to higher position in the oven.
Pie crusts browning too quickly.	Use aluminum foil to cover the edge of the crust and/or reduce baking temperature.	

# USER'S INSTRUCTION

## ACCESSORIES

To order any of these accessories, contact the Whirlpool Service Parts Distributor.

### Hob Protectant

(ceramic glass models)  
Order Part Number 31463A

### Granite Cleaner and Polish

Order Part Number W10275756

### Standard Flat Oven Rack

Order Part Number W10268578

### Hob Scraper

(ceramic glass models)  
Order Part Number WA906B

### Gourmet Griddle

Order Part Number 4396096RB

### Porcelain Broiler Pan and Grid

Order Part Number 4396923

### Premium Broil Pan and Roasting Rack

Order Part Number W10123240

## ASSISTANCE OR SERVICE

Before calling for assistance or service, please check "Troubleshooting." It may save you the cost of a service call. If you still need help, contact the dealer from whom you purchased the appliance, or a Whirlpool designated service company.

When calling, please know the purchase date and the complete model and serial number of your appliance. This information will help us to better respond to your request.

### Serial Plate Key

4	K	W	F	E	7	6	85	E	W	0-9
220-230 V 60 Hz	Emerging Markets	A = Amana M = Maytag W = Whirlpool	F = Free- standing E = Electric	E = Electric R = Free- standing	Flat Door with Extra Large Window	Thermal	5.3 ft <sup>3</sup> (150 L) Pyro, Steam, 5 elements	D = 2014 E = 2015 F = 2016 G = 2017	S = Stainless Steel W = White	Engineering Digit

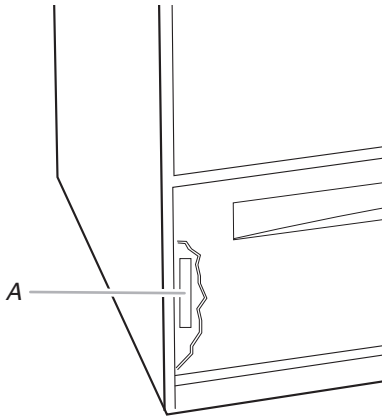

A. Serial plate location

# TECHNICAL FEATURES

## ELECTRIC COMPONENTS

Ref.	Description	ø mm	Nominal Data
C	Radiant single warming element	165	100 W
D	Radiant single heating element	165	1200 W
E	Radiant single heating element	250	2500 W
F	Radiant dual heating element	300	1900/3000 W
	Lower heating element of the oven cooker		2400 W
	Top heating element of the oven-grill cooker		3400 W
	Oven lamp		40 W

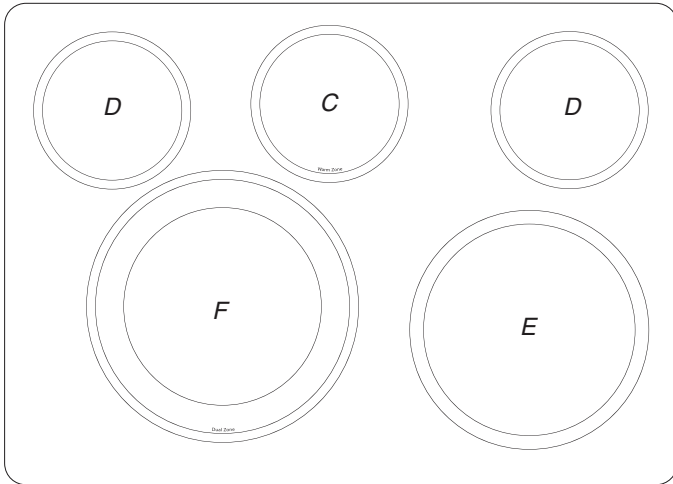

### Cooker Dimensions

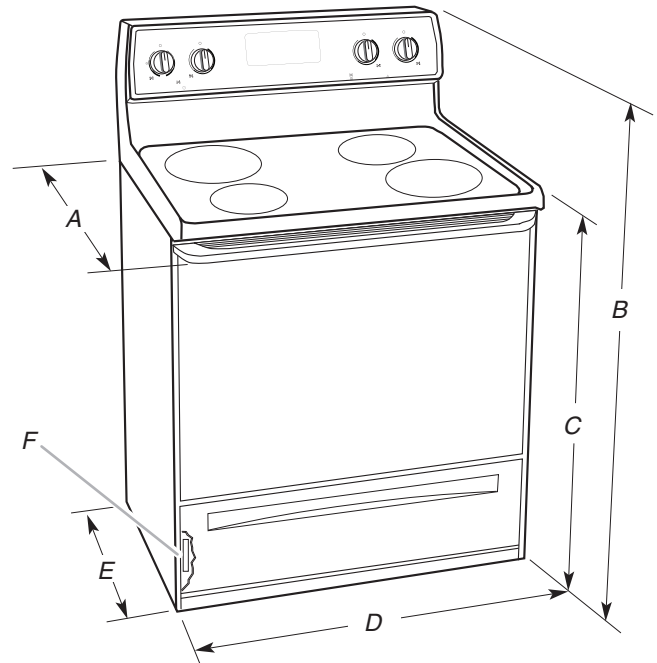

- A. 27<sup>3</sup>/<sub>4</sub>" (70.5 cm) max. depth with handle
- B. 46<sup>7</sup>/<sub>8</sub>" (119.1 cm) overall height (max.) with leveling legs screwed all the way in\*
- C. 36" (91.4 cm) hob height (max.) with leveling legs screwed all the way in\*
- D. 29<sup>7</sup>/<sub>8</sub>" (75.9 cm) width
- E. 25<sup>5</sup>/<sub>16</sub>" (64.3 cm) depth - back of cooker to front of hob\*\*
- F. Model/serial/rating plate (located on the left side frame behind storage drawer)

**IMPORTANT:** Cooker must be level after installation. Follow the instructions in the "Level Cooker" section. Using the hob as a reference for leveling the cooker is not recommended.

\*Cooker can be raised approximately 1" (2.5 cm) by adjusting the leveling legs.

\*\*Front of door and drawer may extend further forward depending on styling.

# INSTRUCTIONS FOR THE QUALIFIED INSTALLER

## INSTALLATION REQUIREMENTS

### Technical Information

- The installation, adjustments, conversions and maintenance operations listed in this book must only be carried out by qualified personnel. The manufacturer cannot be held responsible for any damages to persons or property resulting from an incorrect installation of the appliance.
- The safety and automatic adjustment devices of the appliance may, during its life, only be modified by the manufacturer or duly authorized supplier.
- **IMPORTANT:** To avoid damage to your cabinets, check with your builder or cabinet supplier to make sure that the materials used will not discolor, delaminate or sustain other damage. This cooker has been designed in accordance with the maximum allowable wood cabinet temperatures of 194° (90°C).
- **IMPORTANT:** Observe all governing codes and ordinances.
- To eliminate the risk of burns or fire by reaching over the heated surface units, cabinet storage space located above the surface units should be avoided. If cabinet storage is to be provided, the risk can be reduced by installing a range hood that projects horizontally a minimum of 5" (12.7 cm) beyond the bottom of the cabinets.
- The anti-tip bracket must be installed. To install the anti-tip bracket shipped with the cooker, see "Install Anti-Tip Bracket" section.

### Tools and Parts

Gather the required tools and parts before starting installation. Read and follow the instructions provided with any tools listed here.

#### Tools needed

- Tape measure
- Flat-blade screwdriver
- Phillips screwdriver
- Level
- Hammer
- Hand or electric drill
- Wrench or pliers
- Marker or pencil
- Masking tape
- ¼" drive ratchet
- ¼" nut driver
- ⅜" and ⅝" nut driver
- ⅛" (3.2 mm) drill bit (for wood floors)
- Tin snips or large wire cutters (for cutting ground strap if necessary)

#### Parts supplied

Check that all parts are included.

- 10-32 hex nuts (attached to terminal block) (3)
- Terminal lugs (3)

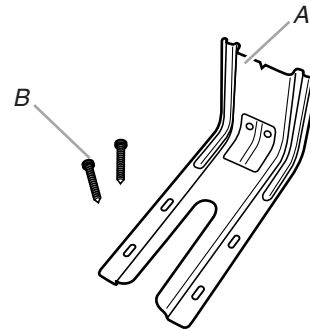

A. Anti-tip bracket  
B. #12 x 1 5/8" screws (2)

- Anti-tip bracket must be securely mounted to floor or wall. Thickness of flooring may require longer screws to anchor bracket to floor.

# INSTRUCTIONS FOR THE QUALIFIED INSTALLER

## INSTALLATION REQUIREMENTS

### Cabinet Dimensions

- Cabinet opening dimensions shown are for 25" (64.0 cm) countertop depth, 24" (61.0 cm) base cabinet depth and 36" (91.4 cm) countertop height.
- Cabinet opening dimensions that are shown must be used. Given dimensions are minimum clearances.
- **IMPORTANT:** If installing a range hood or microwave hood combination above the cooker, follow the range hood or microwave hood combination installation instructions for dimensional clearances above the hob surface.
- A freestanding cooker may be installed next to combustible walls with zero clearance.
- A freestanding cooker must not be placed on a base.

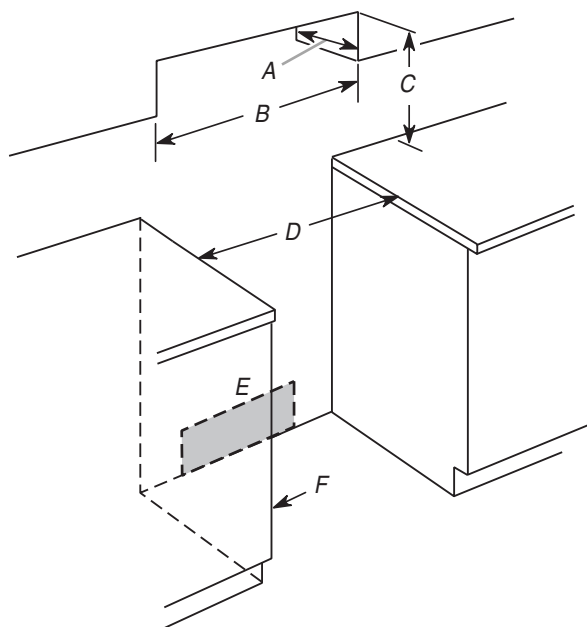

- A. 13" (33.0 cm) max. upper cabinet depth
- B. 30" (76.2 cm) min. opening width
- C. For minimum clearance to top of hob, see NOTE\*.
- D. 30 1/8" (76.5 cm) min. opening width
- E. Outlet - 8" to 22" (20.3 cm to 55.9 cm) from either cabinet, 5 1/2" (14.0 cm) max. from floor
- F. 7/8" (2.2 cm) min. required between cutout and cabinet door or hinge

**\*NOTE:** 24" (61.0 cm) minimum when bottom of wood or metal cabinet is covered by not less than 1/4" (0.64 cm) flame retardant millboard covered with not less than No. 28 MSG sheet steel, 0.015" (0.4 mm) stainless steel, 0.024" (0.6 mm) aluminum or 0.020" (0.5 mm) copper.

30" (76.2 cm) minimum clearance between the top of the cooking platform and the bottom of an uncovered wood or metal cabinet.

### Electrical Requirements

Do not use an extension cord.

Be sure that the electrical connection and wire size are adequate and in conformance with all local codes and ordinances.

**WARNING:** Improper connection of the equipment-grounding conductor can result in a risk of electric shock. Check with a qualified electrician or service technician if you are in doubt as to whether the appliance is properly grounded. Do not modify the power supply cord plug. If it will not fit the outlet, have a proper outlet installed by a qualified electrician.

#### Electrical Connection

To properly install your cooker, you must determine the type of electrical connection you will be using and follow the instructions provided for it here.

- Cooker must be connected to the proper electrical voltage and frequency as specified on the model/serial/rating plate. The model/serial/rating plate is located on the frame behind the left side of the drawer. Refer to the figure in "Cooker Dimensions" in the "Technical Features" section.

Cooker Rating*		Specified Rating of Circuit Protection
		Cable Type: H05 RR-F (194°F [90°C] min.)
		Cross section: 3x4 mm <sup>2</sup>
220 V	230 V	Amps
7.4 - 13.8 kW	8.1-15.1 kW	40

- Allow at least 6 ft (1.8 m) of slack in the line so that the cooker can be moved if servicing is ever necessary.
- Wire sizes and connections must conform with the rating of the cooker.
- The wiring diagram is located on the Tech Sheet.
- The Tech Sheet is located on the back of the cooker inside a clear plastic bag.
- An electrical disconnection must be incorporated into the fixed wiring in accordance with the wiring rules.
- Install an omnipolar switch that can withstand the appliance load with a minimum opening between the contacts of 1/8" (3.2 mm).
- Remember that the earth wire must not be cut out by the switch.

# INSTRUCTIONS FOR THE QUALIFIED INSTALLER

## INSTALLATION INSTRUCTIONS

### Unpack Cooker

#### **⚠ WARNING**

##### Excessive Weight Hazard

**Use two or more people to move and install cooker.**  
**Failure to do so can result in back or other injury.**

1. Remove shipping materials, tape and film from cooker.
2. Remove oven racks and parts package from inside oven.
3. Do not remove the shipping base at this time.

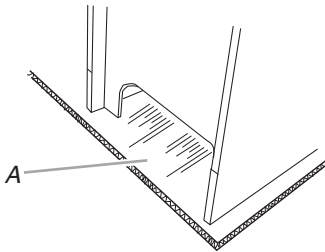

A. Shipping base

4. Remove the storage drawer. See the "Storage Drawer" section. Use a 1/4" drive ratchet to lower the rear leveling legs one-half turn. Use a wrench or pliers to lower front leveling legs one-half turn.

The feet of the appliance are used to adjust the height of the cooker and keep it perfectly horizontal. Adjust the legs by screwing them in or out, as indicated in the following figure. The legs can protrude 1" (2.5 cm) maximum in order to keep the cooker from dropping completely.

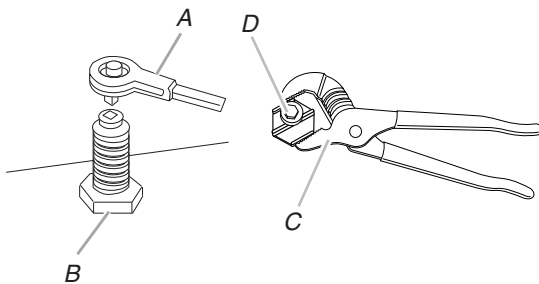

A. 1/4" drive ratchet  
 B. Rear leveling leg

C. Wrench or pliers  
 D. Front leveling leg

### Install Anti-Tip Bracket

#### **⚠ WARNING**



##### Tip Over Hazard

**A child or adult can tip the cooker and be killed.**

**Install anti-tip bracket to floor or wall per installation instructions.**

**Slide range back so rear cooker foot is engaged in the slot of the anti-tip bracket.**

**Re-engage anti-tip bracket if cooker is moved.**

**Do not operate cooker without anti-tip bracket installed and engaged.**

**Failure to follow these instructions can result in death or serious burns to children and adults.**

1. Remove the anti-tip bracket from where it is taped inside the storage drawer.
2. Determine which mounting method to use: floor or wall. If you have a stone or masonry floor, you can use the wall mounting method.
3. Determine and mark centerline of the cutout space. The mounting can be installed on either the left side or right side of the cutout. Position mounting bracket against the wall in the cutout so that the V-notch of the bracket is 12 9/16" (31.9 cm) from centerline as shown.

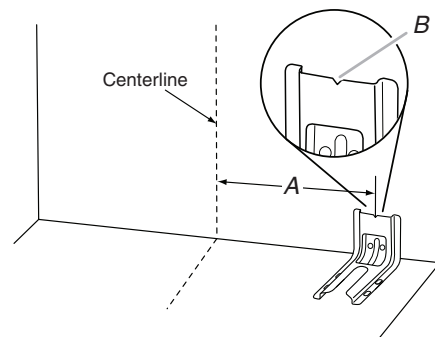

A. 12 9/16" (31.9 cm)  
 B. Bracket V-notch

4. Drill two 1/8" (3.2 mm) holes that correspond to the bracket holes of the determined mounting method. See the following illustrations.

# INSTRUCTIONS FOR THE QUALIFIED INSTALLER

## INSTALLATION INSTRUCTIONS

### Floor Mounting

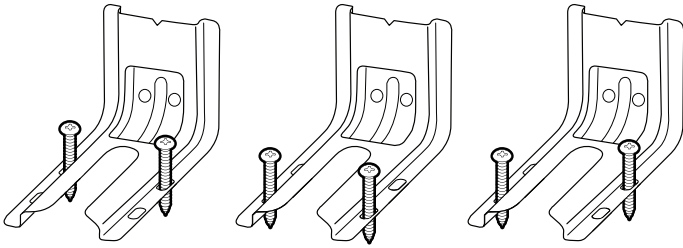

Rear position

Front position

Diagonal (2 options)

### Wall Mounting

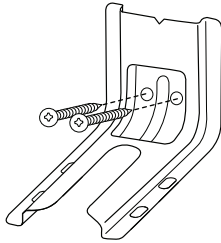

5. Using the two #12 x 1 5/8" screws provided, mount the anti-tip bracket to the wall or floor.
6. Move cooker close enough to opening to allow for final electrical connections. Remove shipping base, cardboard or hardboard from under cooker.
7. Move cooker into its final location, making sure rear leveling leg slides into anti-tip bracket.

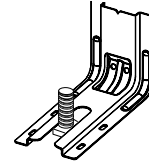

8. Move cooker forward onto shipping base, cardboard or hardboard to continue installing the cooker using the following installation instructions.

# INSTRUCTIONS FOR THE QUALIFIED INSTALLER

## INSTALLATION INSTRUCTIONS

### Electrical Connection

#### Direct Wire

### ⚠ WARNING



#### Electrical Shock Hazard

Disconnect power before servicing.

Electrically ground cooker.

Failure to follow these instructions can result in death, fire, or electrical shock.

1. Disconnect power.
2. Remove the terminal block cover screws located on the back of the cooker. Pull cover down and toward you to remove cover from cooker.

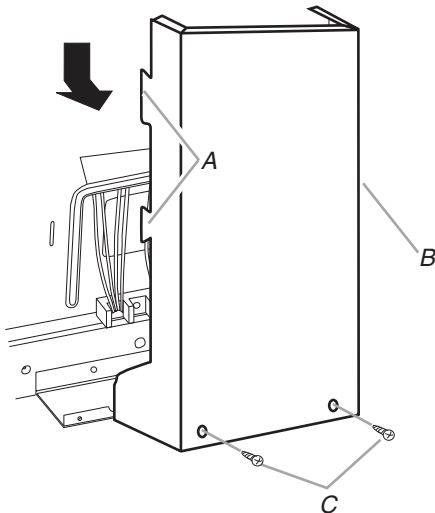

A. Mounting tabs (2 each side)  
B. Terminal block cover  
C. Hex-head screws

3. Remove plastic tag holding three 10-32 hex nuts from the middle post of the terminal block.

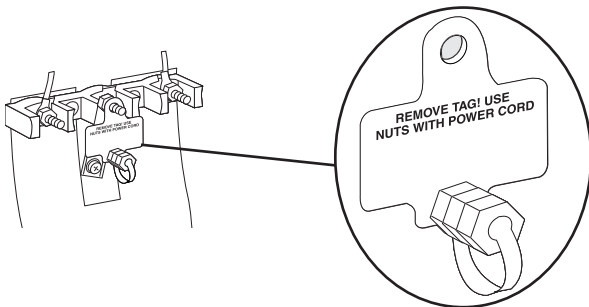

4. Attach terminal lugs to the N (neutral) blue wire, Ⓧ (earth) green/yellow wire, and L (Line) brown wire. Loosen (do not remove) the setscrew on the front of the terminal lug and insert exposed wire end through bottom of terminal lugs. Securely tighten setscrew.

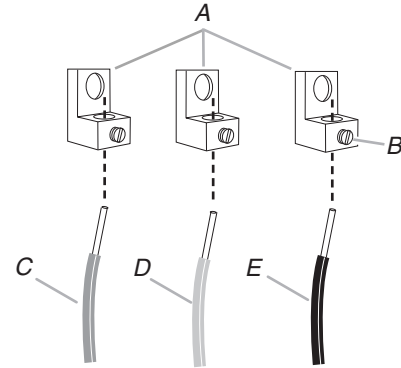

A. Terminal lug  
B. Setscrew  
C. N (neutral) blue wire  
D. Ⓧ (earth) green/yellow wire  
E. L (Line) brown wire

5. Use 3/8" nut driver to connect the Ⓧ (earth) green/yellow wire to the center terminal block post with one of the 10-32 hex nuts.

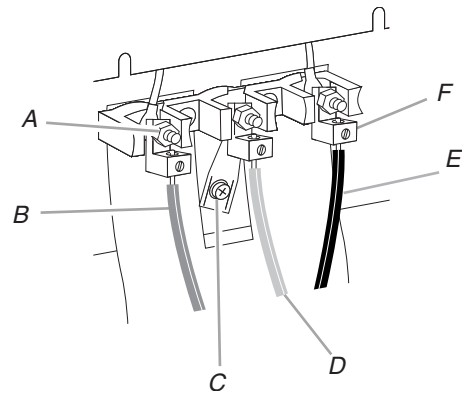

A. 10-32 hex nut  
B. N (neutral) blue wire  
C. Ground-link screw  
D. Ⓧ (earth) green/yellow wire  
E. L (Line) brown wire  
F. Terminal lug

6. Connect N (neutral) blue wire and L (Line) brown wire to the outer terminal block posts with 10-32 hex nuts.
7. Securely tighten hex nuts.
8. Replace terminal block access cover.

# INSTRUCTIONS FOR THE QUALIFIED INSTALLER

## INSTALLATION INSTRUCTIONS

### Verify Anti-Tip Bracket Is Installed and Engaged

1. Remove the storage drawer. See “Storage Drawer” section.
2. Use a flashlight to look underneath the bottom of the cooker.
3. Visually check that the rear cooker foot is inserted into the slot of the anti-tip bracket.

### Level Cooker

1. Place level on the oven bottom as indicated in one of the two figures below, depending on the size of the level. Check with the level: side to side and front to back.

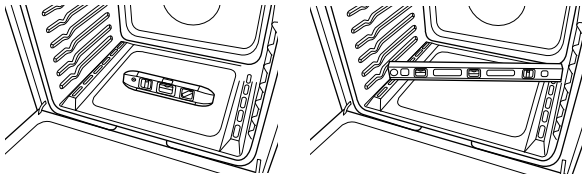

2. If cooker is not level, pull cooker forward until rear leveling leg is removed from the anti-tip bracket.
3. Use a 1/4" drive ratchet, wrench or pliers to adjust leveling legs up or down until the cooker is level. Push cooker back into position. Check that rear leveling leg is engaged in the anti-tip bracket.

### Storage Drawer

The storage drawer can be removed. Before removing, make sure drawer is cool and empty.

#### To Remove:

1. Pull the storage drawer straight back to the drawer stop.

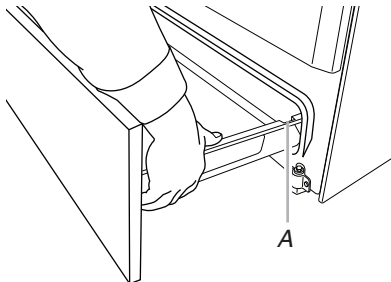

A. Drawer stop notch

2. Lift up the front of the drawer and pull the drawer out.

#### To Replace:

1. Lift up the front of the drawer and place the rear of the drawer inside the cooker so that the drawer stop notch is behind the drawer glide.
2. Lower the drawer so that the edge of the slide rail drops into the slot in the drawer glide.
3. Slowly push the drawer into the cooker.

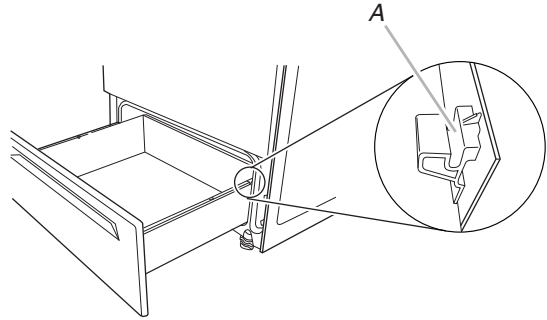

A. Engage drawer glide.

**NOTE:** When properly installed, the rear slides on the bottom of the drawer will engage the base rails and the drawer will not tip when items are placed in the drawer.

### Oven Door

For normal cooker use, it is not suggested to remove the oven door. However, if removal is necessary, make sure the oven is off and cool. Then, follow these instructions. The oven door is heavy.

#### To Remove:

1. Open oven door all the way.
2. Pinch the hinge latch between two fingers and pull forward. Repeat on other side of oven door.

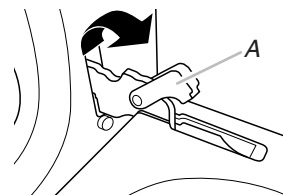

A. Hinge latch

3. Close the oven door as far as it will shut.
4. Lift the oven door while holding both sides.

Continue to push the oven door closed and pull it away from the oven door frame.

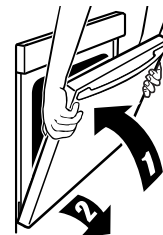

# INSTRUCTIONS FOR THE QUALIFIED INSTALLER

## INSTALLATION INSTRUCTIONS

---

### To Replace:

1. Insert both hanger arms into the door.



2. Open the oven door.  
You should hear a “click” as the door is set into place.
3. Move the hinge levers back to the locked position. Check that the door is free to open and close. If it is not, repeat the removal and installation procedures.

### Complete Installation

1. Check that all parts are now installed. If there is an extra part, go back through the steps to see which step was skipped.
2. Check that you have all of your tools.
3. Dispose of/recycle all packaging materials.
4. Check that the cooker is level. See the “Level Cooker” section.
5. Use a mild solution of liquid household cleaner and warm water to remove waxy residue caused by shipping material. Dry thoroughly with a soft cloth. For more information, read “Cooker Care” in the “User’s Instructions” section.
6. Read the User’s Instructions section.
7. Plug power cord into appropriate outlet. Turn power on.
8. Turn on surface burners and oven. See the “User’s Instructions” section for specific instruction on cooker operation.

### If cooker does not operate, check the following:

- Household fuse is intact and tight; or circuit breaker has not tripped.
  - Cooker is plugged into a grounded outlet.
  - Electrical supply is connected.
- IMPORTANT:** If the cooker control displays an “F9” or “F9, E0” error code, the electrical outlet in the home may be miswired. Contact a qualified electrician to verify the electrical supply.
- See “Troubleshooting” in the “User’s Instructions” section.

When the cooker has been on for 5 minutes, check for heat. If cooker is cold, turn off the cooker and contact a qualified technician.

## Moving the Cooker

### **⚠ WARNING**



#### **Tip Over Hazard**

**A child or adult can tip the cooker and be killed.**

**Install anti-tip bracket to floor or wall per installation instructions.**

**Slide range back so rear cooker foot is engaged in the slot of the anti-tip bracket.**

**Re-engage anti-tip bracket if cooker is moved.**

**Do not operate cooker without anti-tip bracket installed and engaged.**

**Failure to follow these instructions can result in death or serious burns to children and adults.**

When moving cooker, slide cooker onto cardboard or hardboard to avoid damaging the floor covering.

If removing the cooker is necessary for cleaning or maintenance:

### **⚠ WARNING**



#### **Electrical Shock Hazard**

**Disconnect power before servicing.**

**Replace all parts and panels before operating.**

**Failure to do so can result in death or electrical shock.**

1. Disconnect power.
2. Slide cooker forward.
3. Complete cleaning or maintenance.
4. Check that the anti-tip bracket is installed and engaged. See the "Verify Anti-Tip Bracket Is Installed and Engaged" section.
5. Check that cooker is level.
6. Reconnect power.

**W1071772A**  
**AR PN W10720108**

© 2014, Whirlpool Corporation.  
United States of America  
All rights reserved.